



TR 9650 Mobile Bath Lift System

*Hygiene Equipment
Designed for People*

Operating manual

Version 2020-05-01



Registered at Medical Products Agency, Sweden as a MDR Class 1 product according to MDR 2017/745.

TR reserves the right to make design changes and/or improvements without notice.



Always study this manual carefully before you attempt to operate your mobile bath lift. The operator/user must always have access to the operating manual.

This bathing system is intended for professional use only where the patient will be under supervision of trained personnel.

Operating instructions and recommended maintenance procedures are explained in the following pages.

If you have any questions regarding the operation or maintenance of your mobile bath lift system and cannot find the answer in this manual, please contact us.

The system is designed for years of trouble-free operation, with proper use and maintenance.



Mandatory to read the manual before using the equipment



Table of contents

Manufacturer	Page 3
Introduction	Page 4
Unpacking	Page 5
Intended use	Page 6
Safety instructions	Page 7
- General safety instructions	Page 7
- Overload protection	Page 9
- Auto stop mechanism	Page 9
- In case of accident	Page 10
Features and controls	Page 11
- Chair lift	Page 11
- Stretcher- and Combi lift	Page 12
Product description	Page 13
- General product description	Page 13
- Possible configurations with other equipment	Page 14
Technical specification	Page 15
- General technical specifications	Page 15
- Measurements Chair lift	Page 17
- Measurements Stretcher lift	Page 18
- Measurements Combi lift	Page 19
User instructions	Page 20
- Height adjustment	Page 20
- Charging instructions	Page 21
- Attaching the side parts	Page 22
- Castors	Page 23
- Chair backrest	Page 24
- Stretcher side parts	Page 25
- Safety belts	Page 26
- Patient handling	Page 27
- Patient handling – introduction	Page 27
- Patient handling – Transport on chair lift	Page 28
- Patient handling – Transfer from wheelchair onto the chair lift	Page 29
- Patient handling – Transfer from bed onto the chair lift	Page 30
- Patient handling – Chair lift used with bathtub	Page 31
- Patient handling – Transfer from chair lift to bed	Page 32
- Patient handling – Toilet transfer using the chair	Page 33
- Patient handling – Transport on stretcher lift	Page 34
- Patient handling – Transfer from wheelchair onto the stretcher lift	Page 35
- Patient handling – Transfer from bed onto the stretcher lift	Page 36
- Patient handling – Chair lift used with bathtub	Page 37
- Patient handling – Transfer from stretcher lift to bed	Page 38
Labels & symbols on the lift	Page 39



Table of contents

Routine maintenance	Page 41
- Before every use	Page 41
- Daily maintenance	Page 41
- Monthly maintenance	Page 41
- Annual maintenance	Page 41
- Maintenance every 3 years	Page 42
- Maintenance every 5 years	Page 42
Recycling	Page 43
- Batteries	Page 43
- Electric and electrical parts	Page 43
- Metal parts, chassis	Page 43
- Plastic parts	Page 43
- Seat and backrest (PUR)	Page 43
- Packaging	Page 43
Cleaning instructions	Page 44
- General guidelines	Page 44
- Chair lift	Page 45
- Stretcher & Combi lift	Page 46
Training record	Page 47
Maintenance record	Page 48



Manufacturer



TR Equipment AB
Rundelgatan 2
SE-573 35 Tranås
Sweden

Phone: +46 (0)140 38 50 60
www.trequipment.com
info@trequipment.se

Group subsidiaries:

USA

TR Group Inc.

Phone: +1 (800) 7526900

www.trequipment.com

information@trequipment.com

United Kingdom:

TR Equipment Ltd

Phone: +44 (0) 844 335 8386

www.trequipment.com

info@trequipment.co.uk

Germany:

TranspoRehamed GmbH

Phone: +49 (0) 212-645850-0

www.transporehamed.de

info@transporehamed.de



Introduction

Dear Customer,

Thank you for choosing one of our quality products. We hope you enjoy the TR 9650 Mobile bath lift.

This manual shall, in conjunction with staff training, ensure that the operator/user is always using and/or operating the TR 9650 correctly.

New users must be trained by qualified and experienced staff.

TR Equipment AB requires that each user has read and understands the entire operating manual and that they can apply the instructions as specified. This applies to anyone who was not present at the in-service training.

This instruction manual should generally be kept easily accessible for every user. Copying the whole manual is encouraged since its sole purpose is to improve the standard of training and safety.

Please order another copy from us if the instruction manual is lost or unusable, or if it has become illegible over time.

If you need further information, do not hesitate to contact TR Equipment AB or one of our qualified partners.



Mandatory to read the manual before using the equipment.



Make sure you have read, understand, and applied the information on the following pages before using the TR9650 Mobile bath lift.



Unpacking

When you receive a TR 9650 Mobile bath lift from us it's placed on a pallet with a wooden crate wrapped in plastic.



Unpacking the TR 9650 Mobile bath lift:

- Carefully cut and remove the plastic.
- If you have ordered a stretcher lift or a Combi-lift, lift off the box containing the side parts.
- Carefully remove the wooden pieces surrounding the column.
- Unscrew the crate from the pallet and lift it off.
- Unscrew the tie wraps and lift the TR 9650 off the pallet.

Carefully lift the TR9650 Mobile bath lift off the pallet. Never drag or push it off the pallet.



When lifting the lift off the pallet, two people are required.



Intended use

- The **TR 9650** Mobile bath lift is a battery-operated mobile bath lift
- The **TR 9650** Mobile bath lift is intended to ease transferring and bathing of the patient.

Typical situations where the TR 9650 is used includes:

- Transporting the patient to and from a bathing area.
- Bathing and showering the patient in a bathtub.
- Dressing the patient.



The TR9650 shall not be used as a shower equipment.
Showering shall only be performed when the patient is in a bathtub.

- The **TR 9650** is NOT intended to be used with patients that exceed a weight of 150kg.
- The **patient** is typically a person who is unable to take care of their own personal hygiene.
- The **TR 9650** is only intended to be used for short term use <60min when in contact with breached or compromised skin.
- The **TR 9650** is intended to be used indoors in all types of care facilities and private homes, including hygiene areas.
- The **user** is any adult person who is capable of reading and understands the operating manual and is qualified to care for dependent persons/patients.
- Before using the **TR 9650**, the **user** must read and understand the operating manual.



Mandatory to read the Operating manual before using the TR9650 mobile bath lift.



Make sure you have read, understood, and applied the information on the following pages before using the TR 9650 mobile bath lift.



Safety instructions

- Only qualified staff, who understand all operating and safety procedures may operate the equipment.
- When the TR9650 is used in baths always physically check the water temperature before and during bathing and showering.
- The patient must be comfortable on Chair or Stretcher, with **safety belts securely attached**. Safety belts must be maintained in good condition.
- Never let the patient sit on the short ends of the Stretcher.
- Never leave the patient unattended.
- Make sure that all parts that come in contact with the patient are intact and without sharp edges.
- Make sure that the hands of the patient are placed on the proper supports.
- To avoid pinching of arms or fingers during transfer, make sure that the arms of the patient are crossed over his/her body or are firmly grasped on the stabilizing bar on the arm support.
- Operate the TR9650 lift carefully when transporting patients through narrow corridors or over irregular surfaces.
- Wipe beneath Stretcher/Chair to prevent water dripping on the floor after bathing/showering.
- Equipment must be cleaned after every use.



Mandatory to read the Operating manual before using the equipment.



NEVER use the TR9650 lift in any way that varies from the safety precautions and operating procedures detailed in this manual. The TR9650 lift must not be operated by anyone until the user has read and understands the instructions in this manual.



Safety instructions

- Avoid skin or eye contact with detergent, which is highly caustic. If contact is made, rinse immediately with excess water. If irritation occurs, consult a doctor. Always read and follow detergent supplier instructions.
- Never clean pads or pillow in gas sterilization unit, the items may explode.
- It's recommended that the batteries on the lift are charged daily or whenever the lift is not in use. Batteries can't be overcharged.
- The TR battery charger is the only approved charger for the TR 9650 lift.
- Don't use battery charger in wet or damp areas – Potential shock hazard.
- Before you attempt to attach or remove the stretcher side parts, castor brakes must be securely locked.
- Stretchers, seats, all pads etc. must be kept in place, well maintained and all screws should be tightened.
- Make sure that all castors are clean, in place and free from damages.
- Make sure that the safety belts are clean, in place and free from damages.
- Drive belt must be inspected visually for signs of wear. Lifter should not be used if defects are noted. Prompt service is required. If drive belt fails, the stretcher/chair will stop on the column.

If you have questions regarding operation or maintenance of your TR 9650 lift system and can't find the answer in this manual, please contact us!



Mandatory to read the Operating manual before using the equipment.



NEVER use the TR9650 lift in any way that varies from the safety precautions and operating procedures detailed in this manual. The TR9650 lift must not be operated by anyone until the user has read and understands the instructions in this manual.



Safety instructions

Emergency stop:

The TR9650 mobile bath lifts are equipped with an emergency stop in case it's needed to stop the power supply to the motor. If needed, press the emergency stop with your foot and the power supply will be shut off.

It's not possible to raise or lower the lift if the emergency stop is activated. Turn the emergency stop clockwise to release it.

During battery charging, make sure that the emergency stop is released otherwise the batteries won't be charged.

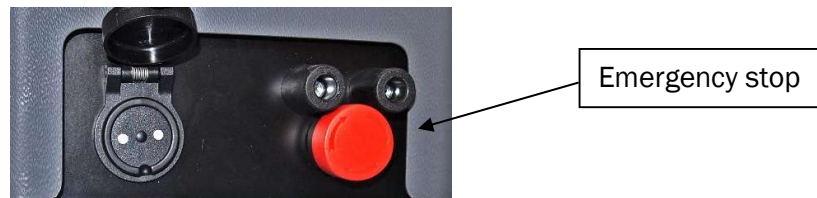

Auto stop mechanism:

The auto stop mechanism is of great importance and will lock the chair/stretcher to the column if the drivebelt brakes.

If the chair or stretcher hits an obstacle when lowering, the lift will automatically stop. To release the chair or stretcher from this position, press UP symbol on the foot pedal.

If the drive belt is slacking (see picture below), press the UP symbol on the foot pedal until a click is heard.

If the drive belt fails (cuts off), the chair or stretcher will automatically stop/lock on the column.





Safety instructions

Note:

In case of a serious incident when using the TR 9650 mobile bath lift, this should be reported to the manufacturer and to the local authorities where you are established.



TR Equipment AB
Rundelgatan 2
SE-573 35 Tranås
Sweden

www.trequipment.com

info@trequipment.se

Phone: +46 (0)140 38 50 60

Group subsidiaries:

USA

TR Group Inc.

Phone: +1 (800) 7526900

www.trequipment.com

information@trequipment.com

United Kingdom:

TR Equipment Ltd

Phone: +44 (0) 844 335 8386

www.trequipment.com

info@trequipment.co.uk

Germany:

TranspoRehamed GmbH

Phone: +49 (0) 212-645850-0

www.transporehamed.de

info@transporehamed.de



Features and controls

Chair lift

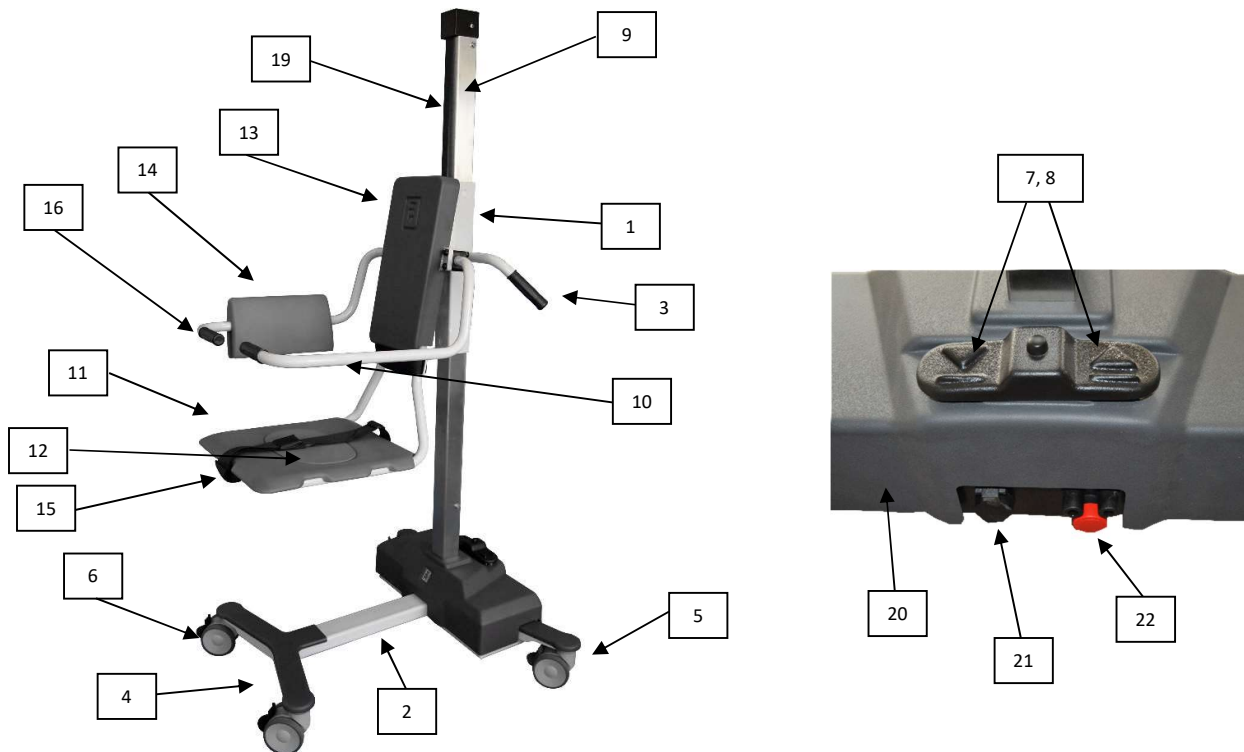

1	Support column
2	Chassis base
3	Transfer handle
4	Chassis legs
5	Castors with brake Grey pedal
6	Castors with straight steering Black pedal
7	Foot control DOWN
8	Foot control UP
9	Stainless steel column
10	Rotating arm/back supports
11	Hygiene seat

12	Seat lid
13	TR protection cover
14	Backrest pad
15	Safety belt
16	Transport grip
19	Drive belt
20	Low battery audible tone
21	Battery charger input
22	Emergency stop



Features and controls

Stretcher Lift & Combi lift

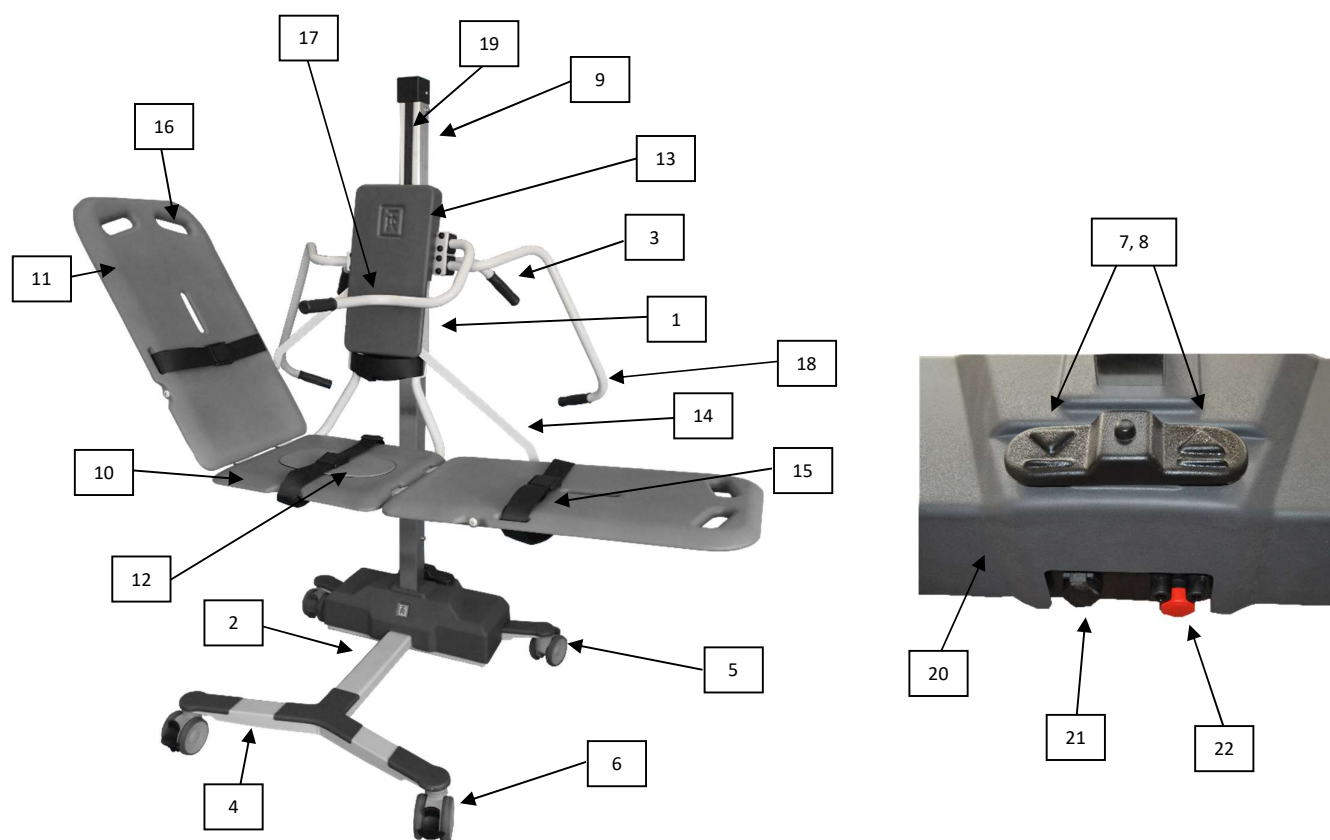

1	Support column
2	Chassis base
3	Transfer handle
4	Chassis legs
5	Castors with brake Grey pedal
6	Castors with straight steering Black pedal
7	Foot control DOWN
8	Foot control UP
9	Stainless steel column
10	Hygiene seat
11	Stretcher side parts

12	Seat lid
13	TR protection cover
14	Stretcher attachment and position setting bars
15	Safety belts
16	Transport grip
17	Stabilizing bar
18	Arm/back support
19	Drive belt
20	Low battery audible tone
21	Battery charger input
22	Emergency stop



Product description

The TR9650 is a battery-operated mobile bath lift and is available in three different designs.

TR9650 - Chair lift, part number 0542000

Battery operated height adjustable with chair.
Batteries, battery charger and safety belts are included.
Equipped with two straight steering castors and two castors with brake.

TR9650 has narrow front legs and can't be combined with stretcher side parts!



TR9650 – Stretcher lift, part number 0542010

Battery operated height adjustable with stretcher.
Batteries, battery charger, pillow and safety belts are included.
Equipped with two straight steering castors and two castors with brake.



TR9650 – Combi lift, part number 0542020

Battery operated height adjustable with chair.
Possible to use as a stretcher by assembling side parts.
Batteries, battery charger and safety belts are included.
Equipped with two straight steering castors and two castors with brake.



Side parts incl. pillow and safety belts are bought separately.

TR9650 – Side parts, part number 0542030.

Stretcher side parts for combi lift including pillow and safety belts.





Product description

Possible equipment combinations	
TR9650 – Chair lift	TR Comfortline II / TR Ecoline II / TR900 / TR1700
TR9650 - Stretcher lift	TR Comfortline II / TR Ecoline II / TR900
TR9650 – Combi lift with side parts	TR Comfortline II / TR Ecoline II / TR900
TR9650 – Combi lift without side parts	TR Comfortline II / TR Ecoline / TR900 / TR1700



TR9650 – Chair lift



TR9650 – Stretcher lift



TR9650 – Combi lift with side parts



TR9650 – Combi lift without side parts



TR1700 bathtub



TR Comfortline bathtub



TR Ecoline bathtub



TR900 bathtub



Technical specification

TR9650 Mobile bath lift

Supply voltage	24 VDC, 7Ah
Maximum working load	150Kg
Operating range	200 - 965mm / 7" - 38"
Height (all models)	1730mm / 68"
Width Chair lift	880mm / 34 5/8"
Depth Chair lift	795mm / 31 1/2"
Width Stretcher lift	1940mm / 76 3/8"
Depth Stretcher lift	810mm / 31 7/8"
Width Combi lift without side parts	880mm / 34 5/8"
Depth Combi lift without side parts	810mm / 31 7/8"
Width Combi lift with side parts	1940mm / 76 3/8"
Depth Combi lift with side parts	810mm / 31 7/8"
Weight Chair lift	60Kg / 132,3 lbs
Weight Stretcher lift	76kg / 167,5 lbs
Weight Combi lift without side parts	63kg / 138,9 lbs
Weight Combi lift with side parts	77kg / 169,8 lbs
Weight Side parts	14kg / 30,9 lbs
Castors	Twin castors Ø100mm / 4"
Pillow	Flame retardant material
Hygiene seat and side parts	PUR (Poly Urethane)
Structure	Powder coated, zinc plated and stainless steel
Battery	Lead-acid, rechargeable
Battery charger input	100-240VAC, 50/60Hz
Battery charger output	24VDC
Protection class	IP X4
Control	Foot control for height adjustment

Transport and storage

Ambient temperature	-20°C - +70°C -4°F - +158°F
---------------------	--------------------------------



Technical specification

TR9650 – Chair lift

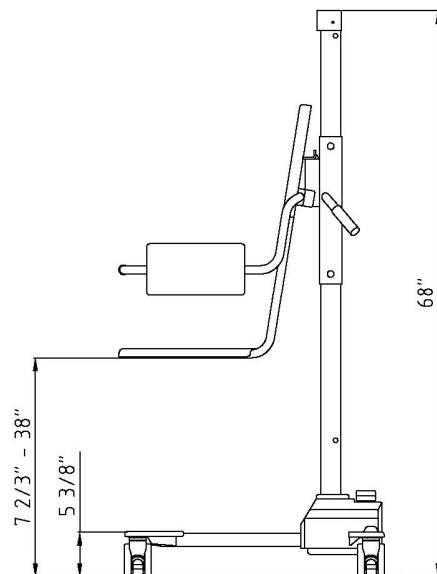
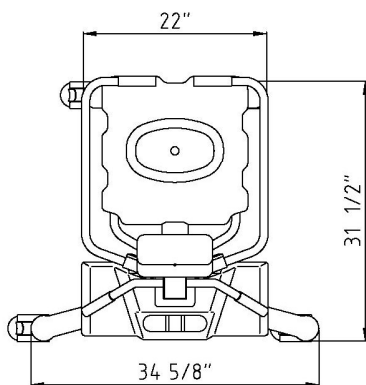
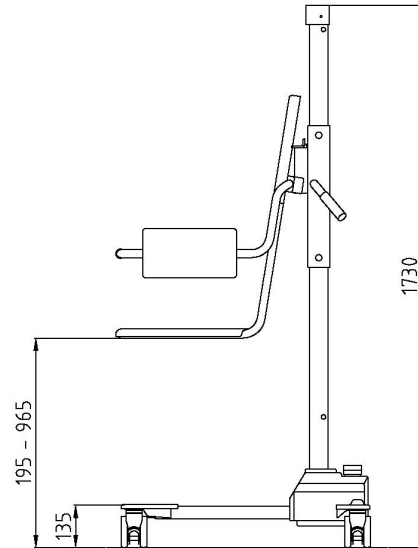
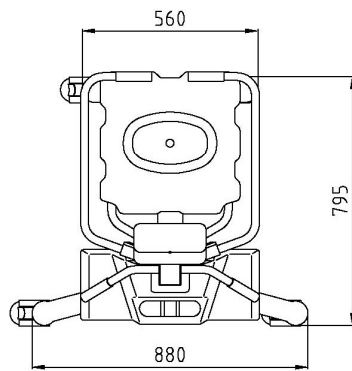



Technical specification

TR9650 - Stretcher lift

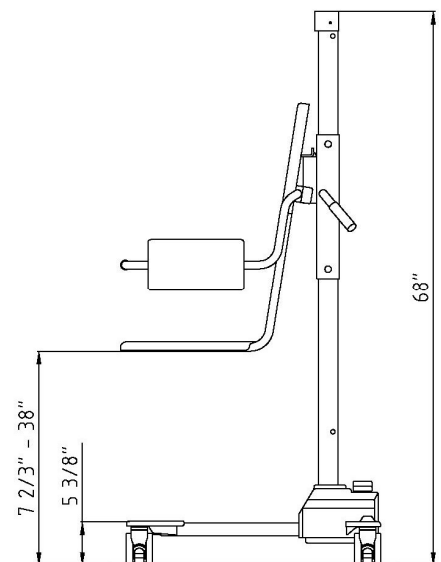
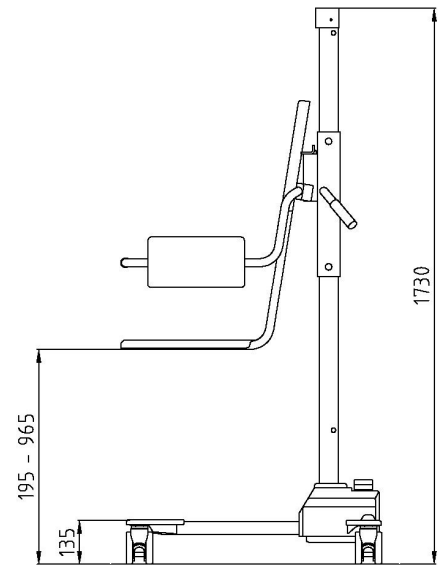
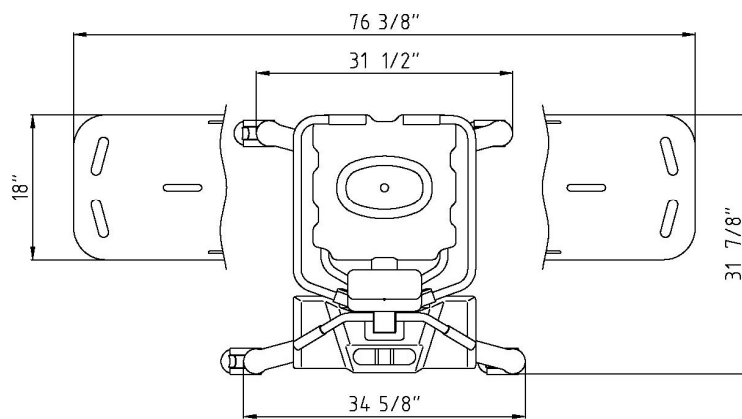
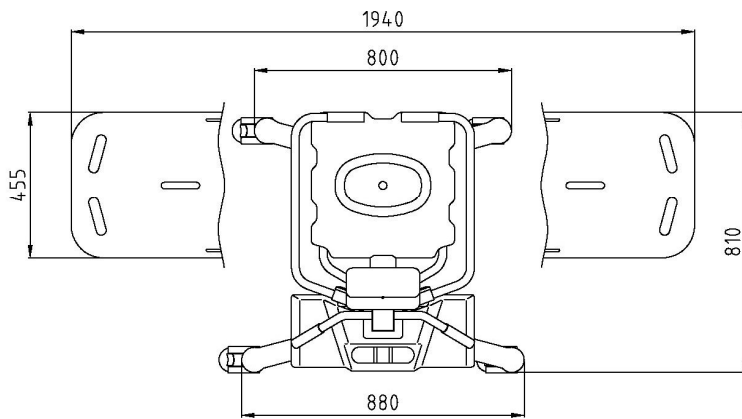



Technical specification

TR9650 - Combi lift

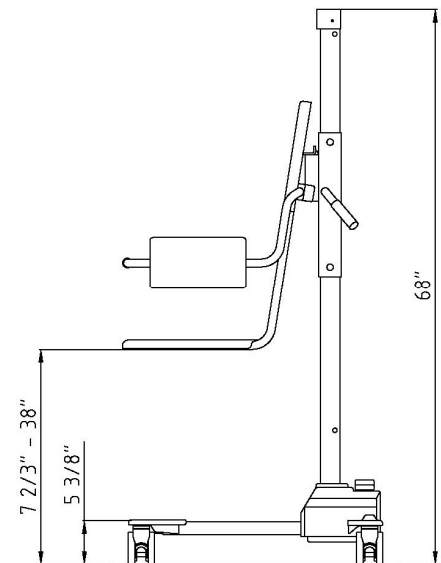
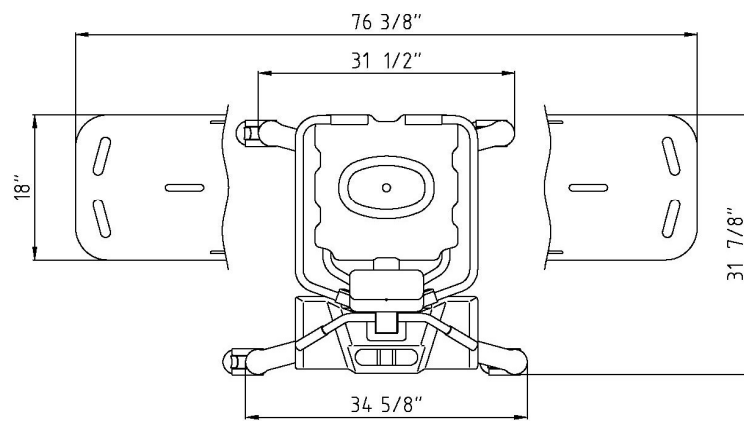
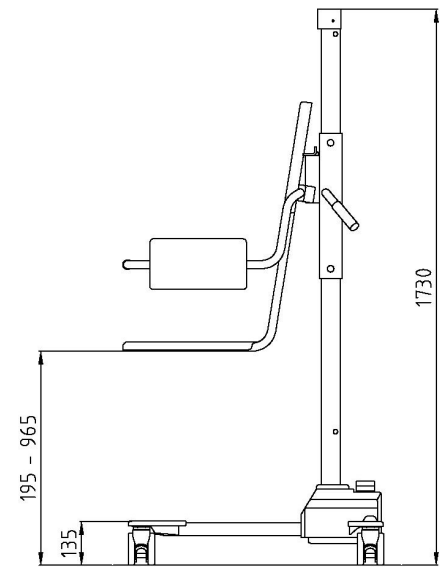
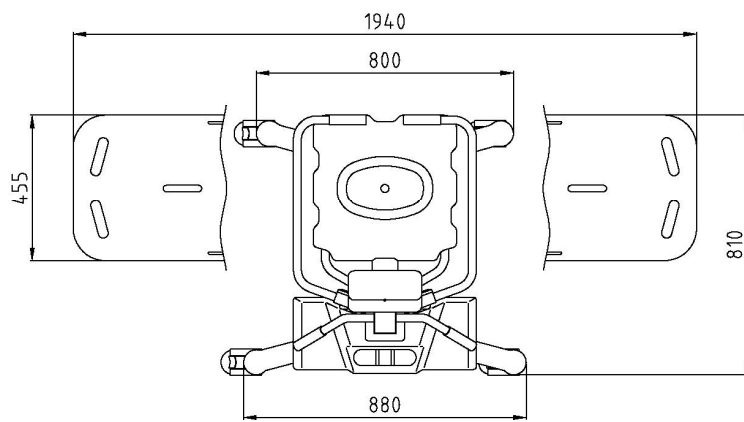



User instructions

Height adjustment:

Raise or lower the chair or stretcher lift by using the foot pedal on the plastic cover.

Raise the chair or stretcher by pressing the UP symbol on the foot pedal.

Lower the chair or stretcher by pressing the DOWN symbol on the foot pedal.

The chair or stretcher raises and lowers smoothly while pressing the foot pedal with your foot and stops immediately when you stop pressing the foot pedal.

When the chair or stretcher hits the top position an audible tone will sound. Press the DOWN symbol on the foot pedal to lower the seat or stretcher.



Always check the water temperature by hand or using a bath thermometer before lowering the patient into a bathtub.



User instructions

Charging instructions:

Charge the lift daily or when the low battery audible tone sounds, when pressing the UP symbol on the foot pedal. The batteries can't be overcharged. The battery charger is equipped with a magnetic connector to avoid damages on the charger if the Mobile bath lift will be moved during charging.

- Use only the charger supplied by TR Equipment.
- The Emergency stop can't be activated during charging. If the emergency stop is activated the batteries won't be charged.
- Connect the charger to the lift **before** connecting the charger to the mains supply.
- When the battery charger is properly connected the charging indicator on the charger will be lit. If not, make sure the plug on the charger is properly connected.
- The charging indicator shows the charging cycles. Yellow while charging and Green when the batteries are fully charged.
- Minimum charging time is 8 hours. The batteries can't be over charged.
- When the charging is completed, disconnect the charger from the mains, before you disconnect the charger from the lift.
- A flat fuse (15A) is connected between the batteries. The batteries are placed under the plastic cover.

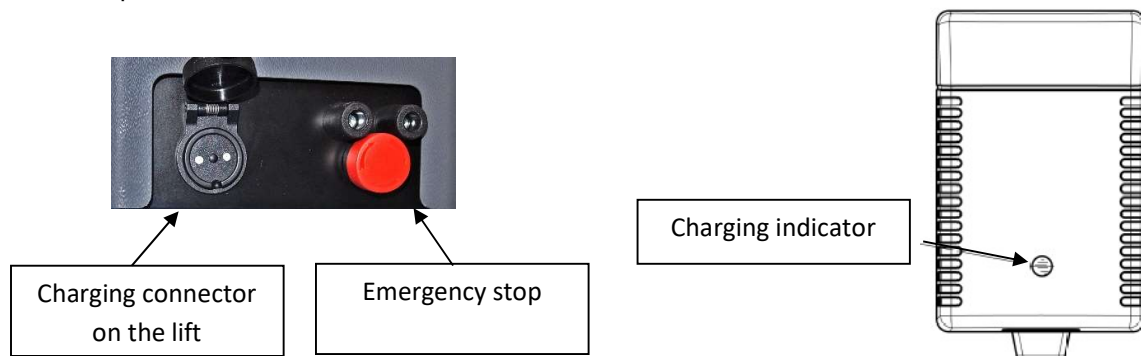



User instructions

Attaching the side parts on Stretcher and Combi lift:

- Lock the castors and open the chest safety belt on the chair.
- Remove the TR protection cover by pulling it straight out at the top. Lower the TR protection cover a little bit and remove it. You will now see the adjustment bracket behind the TR protection cover.
- Raise or lower the chair on the lift, by pressing the foot pedal to a suitable working height and an easier attachment. The chair must be at least 90cm / 36" above floor for easy attachment.
- Attach the side parts on the hinges on the chair. Attach one side part at a time.
- Raise the side parts and attach the setting bar to the adjustment bracket.
- Attach the TR protection cover again.
- To remove the side parts, do every step in a reverse way.



TR Protection cover



Hinges

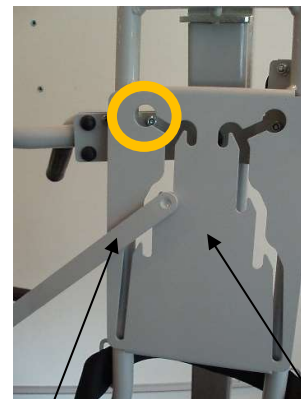

Setting bar

Adjustment bracket



Never use the lift with stretcher side parts attached without the TR protection cover securely in place. This is to avoid pinch injuries and the risk for the setting bars to come out from the adjustment bracket.



User instructions

Castor with brakes:

The TR9650 mobile bath lift are equipped with two castors with brake and they have a Grey pedal.

- To activate the brake, press the pedal DOWN with your foot.
- To release the brake, push the UP with your foot.
- To increase stability also press the black pedals on the straight steering castors DOWN.

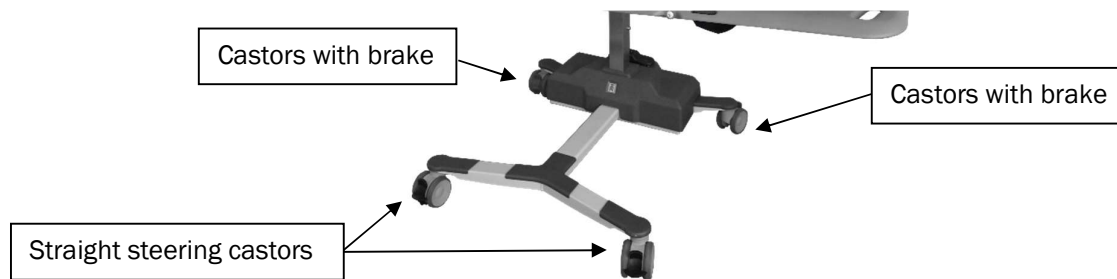

Castor with straight steering function:

The TR9650 mobile bath lift are equipped with two straight steering castors and they have a Black pedal.

Lock the straight steering castor facing the direction you are moving.

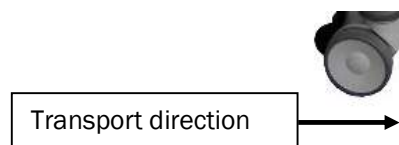

- To activate the straight steering function, press the pedal DOWN with your foot. You will hear a click when it's in position.
- To release the straight steering function, push the pedal UP with your foot.



User instructions

Chair backrest:

For better versatility during patient transfer, patients can be oriented in either direction on the chair. Simply switch the backrest pad from one rotation arm support over to the other.

The chair has a TR protection cover which temporary can be used as a backrest and enables the patient to easily be positioned for transport.

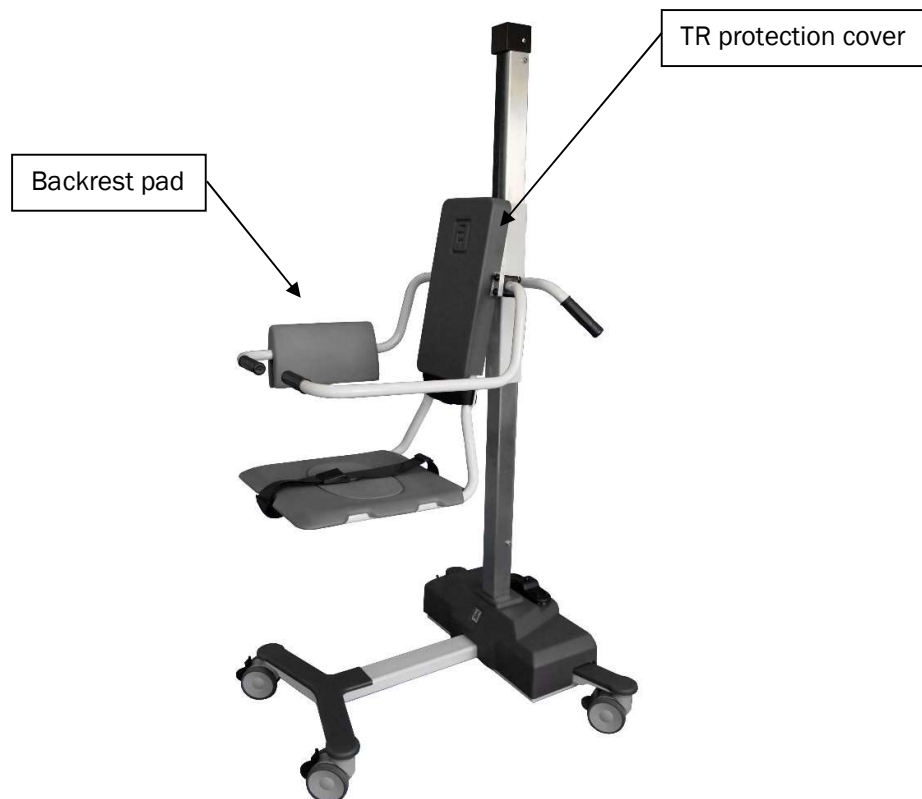



User instructions

Stretcher side parts:

For better versatility during patient transfer, patients can be oriented in either direction on the stretcher. Simply switch the head pillow from one rotation arm support over to the other and note that a hinged side part operates either way on the stretcher.

Raise either side part by lifting it slightly and lift the setting bar into position. The setting bar automatically latches into either angled position.

Lower either side part by lifting it slightly, grasp and lift the setting bar and lower the side part to desired position.



Warning

Before adjusting the angle of the side parts, activate the brake on the castors and ensure that the setting bar is fully in place in either position before moving the TR9650 lift again.





User instructions

Safety belts:

Chair lift:

When a patient is seated on the chair, place the adjustable safety belts around the patient's chest and legs. Run the belt ends through the guides on the chair. Adjust the safety belts to ensure comfort and safety for the patient. Then tighten and fasten the safety belts securely.

Stretcher- / Combi lift

When the patient is placed on the stretcher, place the two adjustable safety belts over the patient's chest and legs. Adjust the safety belts to ensure the comfort and safety for the patient. Then tighten and fasten the safety belts securely.



Chair lift

Stretcher- / Combi lift



User instructions

Patient handling – Introduction



Warning

Never leave patient unattended at any time.



Warning

Safety belts must be securely fastened around the patient at all times.



Warning

Always check the water temperature by hand or using a bath thermometer before lowering the patient into a bathtub.



Warning

Wipe beneath Stretcher to prevent water dripping on floor.



Warning

Before adjusting the angle of the side parts, activate the brake on the castors and ensure that the setting bar is fully in place in either position before moving the TR9650 lift again.



Warning

Never use the lift with stretcher side parts attached without the TR protection cover securely in place. This is to avoid pinch injuries and the risk for the setting bars to come out from the adjustment bracket.



User instructions

Patient handling - Transport on chair lift

To ensure safety, patients shall be transported on the chair lift following the recommended procedures below.
Note: For the following special transfer procedures with the chair lift, patients can be pivoted on the chair lift seat and rest against the attached back protection pad.

- Lock the castors with brake by pressing the Grey pedal on the castor DOWN.
- Adjust the backrest pad for better comfort.
- Assist the patient to be seated comfortably on the chair lift seat.
- Adjust the safety belts around the patient's chest and legs and fasten them properly.
- Raise the chair lift seat to transport comfortable transport position by pressing the UP symbol on the foot pedal with your foot.
- The patient shall grasp the grip on the arm support for extra safety and support.
- Unlock the castors with brake by pushing the Grey pedal upwards, and if desired, activate one of the straight steering castors to ease transporting.

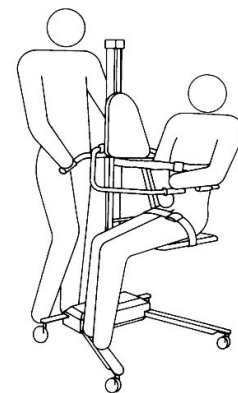

Transport direction



- When transporting, push the chair lift with one hand on the transfer handle and your other hand on the rotating arm/back support, behind the patient.



User instructions

Patient handling – Transfer from wheelchair onto the chair lift

You can raise or lower the Chair to match wheelchair seat heights.

- Lock the castors with brake by pressing the Grey pedal on the castor DOWN. Lift and rotate the arm support to the rear position.
- Position the wheelchair next to the chair lift seat and lock the wheelchair wheels.
- Lower the chair lift seat to wheelchair seat height by pressing the DOWN symbol on the foot pedal.
- Remove the wheelchair armrest and remove or swing footrest away on the transfer side.
- Transfer the patient laterally from the wheelchair to the chair lift seat, supporting the patient's under arms. Note: Backrest pad on rotating arm support shall be in its regular transport position during the transfer.
- Position patient comfortably on the chair lift seat with the back against the backrest pad.
- Rotate the arm support forward and secure safety belts around the patient's chest and legs.
- Raise the chair lift seat to a comfortable transport position by pressing the UP symbol on the foot pedal.
- Unlock the castors with brake by pushing the Grey pedal upwards, and if desired, activate one of the straight steering castors to ease transporting.

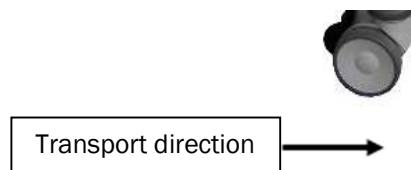
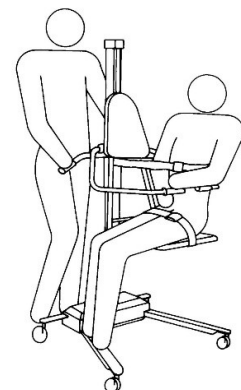
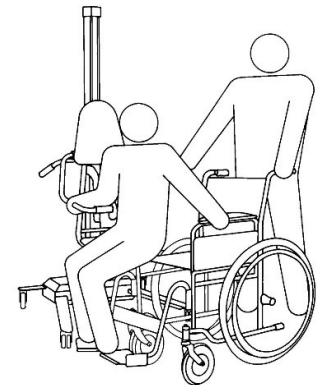
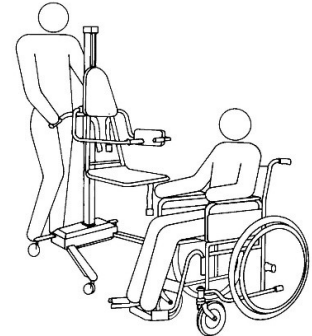

To return patient to wheelchair reverse the steps.



User instructions

Patient handling - Transfer from the bed onto the chair lift

Follow the recommended procedures. Do not omit any steps. Stay in sequence.

- Lower the bed side rail on the transfer side and make sure that the bed side on the opposite side is raised and locked into position.
- Position the chair lift seat over the bed,
- Rotate both arms back support to their rear positions.
- Roll the patient onto his/her side, facing away from the chair.
- Position the Chair over the bed so that the seat is aligned with the patient buttocks.
- Lower the chair lift seat. The lowering will automatically stop when chair lift seat hits the bed surface.
- Lock the castors with brake by pressing the Grey pedal on the castor DOWN.
- Roll the patient over, onto a comfortable position on the chair lift seat. Rotate the forward arm support into its transport position in front of the patient.
- Assist the patient to a sitting position and have him/her to firmly grasp the arm support. If the patient is in an electric bed, raise the bed head end to assist the patient. With the patient sitting, rotate the arm support with the backrest forward and let patient rest against it.
- Adjust safety belts around the patient's chest and legs and fasten them.
- Raise the Chair from the bed mattress and unlock the castors with brake by pushing the Grey pedal upwards.
- Support the patient's legs with one arm, roll the chair lift seat away from the bed, and then lower the patient's legs.
- Raise or lower the Chair to convenient height.
- Push the Chair Lift by using the transfer handle and the arm support behind the patient.
- If desired, activate one of the straight steering castors to ease transporting.

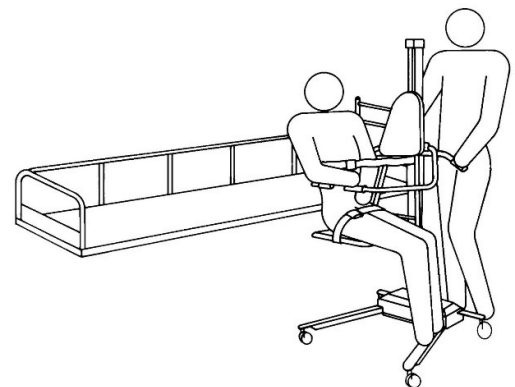
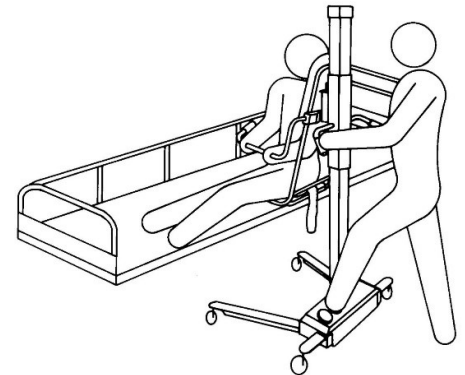
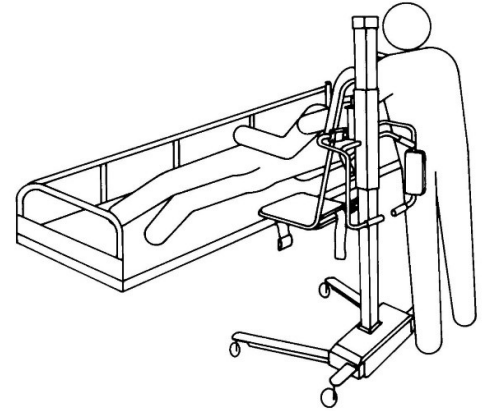

Transport direction →



User instructions

Patient handling - Chair lift used with bathtub

When bathing, the patient must always remain on the Chair with safety belts securely fastened.

- Position the chair Lift next to the prefilled bathtub.
- Lower the bathtub and raise the chair lift seat high enough by pressing the UP symbol on the foot pedal with your foot to clear the bathtub rim.
- Support the patient's legs clear of the bathtub rim with one arm and position the chair lift seat over the bathtub.
Note: Raise the chair lift seat by pressing the UP symbol on the foot pedal to ensure clearance of all body parts over the bathtub rim. Also, make sure the patient's hands firmly grasp the arm support or cross the arms over his/her body. This to avoid any possibility of the patient being pinched between the rim of the bathtub and chair lift seat during the transfer.
- Lower the patient's legs into the bathtub.
- Raise the bathtub to a comfortable working height and lower the chair lift seat into the water by pressing the DOWN symbol on the foot pedal until the chair lift seat is resting on the bathtub bottom and lock the castor brakes.
- When the patient is comfortable in the water, rotate one or both arm supports over the bathtub rim to allow the patient to recline, if the patient is capable of self-support. The bathtub has an adjustable footrest for more comfort and security.
- After bathing, rotate the forward arm support into transport position in front of the patient.
- Assist the patient to a sitting position and have him/her firmly grasp the arm support. Rotate the arm support with the backrest pad forward and let patient rest against it.
- Lower the bathtub and raise the Chair above water level. You can use patient shower system to rinse the patient in this position, and the water will drain into the bathtub.

- Raise the chair lift seat by pressing the UP symbol on the foot pedal with your foot, to clear tub rim and support patient's legs.
Unlock the castors with brake by pushing the Grey pedal upwards with your foot and pull the Lift away from the bathtub.
- Lower the chair to a suitable transport height by pressing the DOWN symbol on the foot pedal with your foot. The patient can then be dried and wrapped in a bath towel.
Note: Wipe beneath Chair to prevent water dripping on the floor.
- If desired, activate one of the straight steering castors to ease transporting.

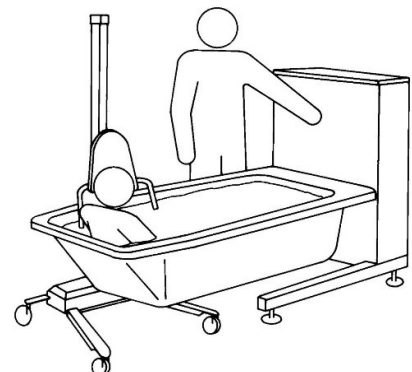
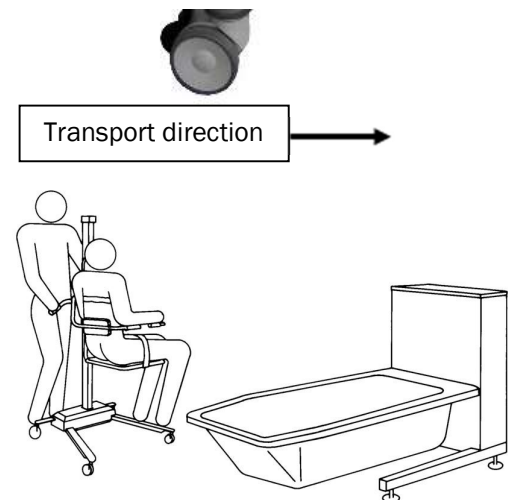



User instructions

Patient handling - Transfer from chair to bed

- Lower the bed side rail on the transfer side and make sure that the side rail on the opposite side is raised and locked into position.
- Support the patient's legs with one arm to clear the bed mattress as you position the chair lift seat over the bed. Lock the castor brakes.
- Lower the chair lift seat. The seat will automatically stop when hitting the bed surface.
- Make sure patient firmly grasps the arm support.
- Loosen the safety belts.
- Support patients back with one arm and rotate rear arm support with backrest pad out of way. Lower patient back into bed.
- Rotate forward arm support behind Chair.
- Roll the patient gently over in the bed.
- Raise chair lift seat. Unlock the castors with brake and move the chair lift away from bed.
- Roll patient to a comfortable position in the bed.
- Raise and lock bed guard rail on the transfer side.

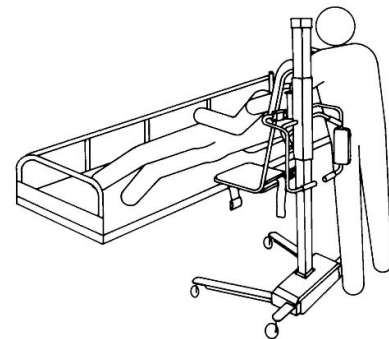
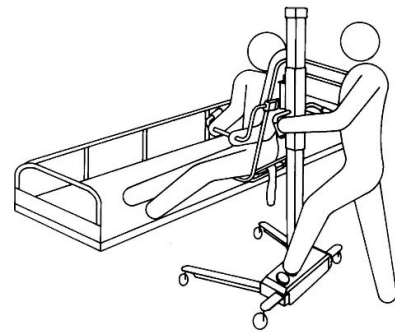



User instructions

Patient handling - Toilet transfer using the chair

The chair lift can be used for wall mounted toilets. Remove the seat lid on the lift.

1. Lift the toilet seat and place the chair lift seat the same way as going into a bath, over the bowl.
2. Lock the castors with brake and lower the chair seat, by pressing the DOWN symbol on the foot pedal.

The hygiene seat enables the patient to be washed in the perineum area.





User instructions

Patient handling - Transport on stretcher

To ensure safety, patients shall be transported on Stretcher following the special recommended procedures.

The stretcher can always be lowered to the lowest position.

- Lock the castor brakes
- Adjust the stretcher side part to a comfortable position.
- Support the patient's comfort on the stretcher.
- Adjust the chest- and leg safety belts and fasten them.
- Adjust the stretcher to a comfortable transport height by pressing the UP or DOWN symbol on the foot pedal.
- Allow the patient to firmly grasp the stabilizing bar for extra safety and support.
- Unlock the castor brakes and, if desired, activate the straight steering castor when transporting.
- When transporting a patient on the Stretcher, push the TR9650 lift with one hand on the transfer handle on the column and the other hand in the stretcher side part opening behind the patient.

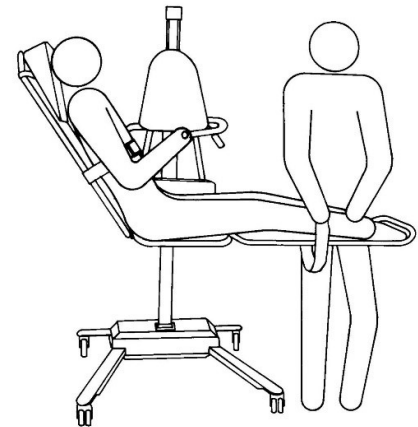
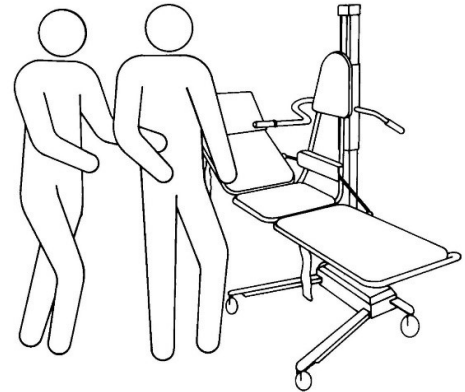



User instructions

Patient handling - Transfer from wheelchair onto the stretcher.

You can raise or lower the stretcher to match the height of the wheelchair and thus ease the transfer for patients in a wheelchair.

- Lock the castors with brake and raise the stretcher backrest part to an upright position.
- Position the wheelchair next to the stretcher and lock the castors on the wheelchair.
- Lower the stretcher to the wheelchair height, by pressing the DOWN symbol on the foot pedal.
- Remove the wheelchair armrest and remove or swing the wheelchair footrest on the transfer side.
- Transfer the patient laterally from the wheelchair onto the stretcher, supporting the patient under arms.
- Position patient comfortably on the Stretcher, secure the safety belts and raise Stretcher to a transport position, by pressing the UP symbol on the foot pedal with your foot.
- Unlock the castors with brake and, if desired, activate one of the straight steering castors to ease transporting.





User instructions

Patient handling - Transfer from stretcher lift to bed

Follow the recommended procedures. Do not omit any steps. Stay in sequence.

- Lower the bed side rail on the transfer side and make sure that the bed side rail on the opposite side is raised and locked into position.
- Position the stretcher over the bed, Lock the castors with brake by pressing the Grey pedal on the castor DOWN.
- Roll the patient onto his/her side, facing away from the stretcher and parallel to the stretcher.
Note: Position patients on the bed mattress so that the stretcher can be placed close to the patient's back for transfer.
- Position the stretcher over the bed and lower it, by pressing the DOWN symbol on the foot pedal onto the mattress. The lowering will automatically stop when stretcher hits bed surface.
- Lock the castors with brake.
- Roll the patient over, onto a comfortable position on the stretcher.
- Raise the stretcher slightly, by pressing the UP symbol on the foot pedal with your foot and secure the safety belts around the patient's chest and legs.
- Raise the stretcher side part to a comfortable position using the end support and latch the setting bar.
- Raise the Stretcher by pressing the UP symbol on the foot pedal.
- Unlock the castors with brake.
- Pull the lift from the bed, using the transfer handle and adjust the stretcher to a comfortable transport height on column.
- Push the lift by using the side part opening and transfer handle.
- If desired, activate one of the straight steering castors to ease transporting.

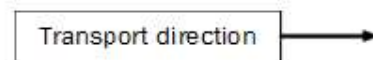
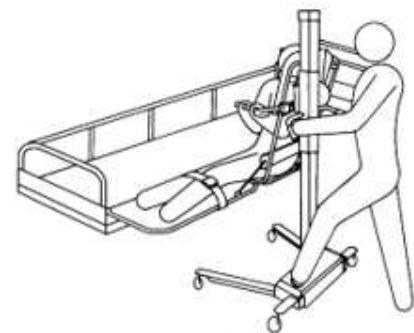



User instructions

Patient handling - On Stretcher into Bathtub

When bathing, the patient must always remain on the stretcher, with safety belts securely fastened. Backrest must be in full upright position when the stretcher is lowered into the bathtub and foot support in the bathtub must be removed.

- Use the transfer handles to place the lift next to the prefilled bathtub.
- Lower the bathtub and raise the stretcher high enough to clear the tub rim.
Important: Make sure that patient's hands grasps the stabilizing bar or that the patient's arms are crossed over his/her body. This to avoid pinching arms or fingers between stretcher frame and tub rim when stretcher is lowered, or if the tub is raised.
- Position the stretcher so it is centered over the tub.
- Raise the bathtub to a comfortable working height before lowering the stretcher and patient into the water.
- After bathing, lower the bathtub before raising the stretcher. You can use the patient shower system to rinse the patient in this position, allowing the water to drain into the bathtub.
- Raise stretcher to clear the tub rim and pull it away from the bathtub. Lower the stretcher to convenient transport height. The patient can then be dried and wrapped in a bath towel.
- If desired, activate one of the straight steering castors to ease transporting



Transport direction





User instructions

Patient handling - Transfer from the stretcher lift onto the bed

- Lower the bed side rail on the transfer side and make sure that the bed side on the opposite side is raised and locked into position.
- Position the stretcher over the bed, Lock the castors with brake by pressing the Grey pedal on the castor DOWN.
- Lower the stretcher onto the mattress. The stretcher will automatically stop when hitting the bed surface.
- Lower the stretcher backrest onto the bed mattress.
- Loosen the safety belts.
- Roll the patient gently onto the bed.
- Raise the stretcher slightly to clear the mattress.
- Unlock the castors with brake by pushing the Grey pedal upwards.
- Roll the patient into a comfortable position on the bed.
- Raise and lock the bed guard rail on transfer side.













Labels and symbols



Product label



 TR EQUIPMENT	TR Equipment logotype
	Medical equipment according to MDR 2017/745
	CE marking
	Factory address
	Manufacturing date
	Part number
	Serial number
	Mandatory to read the operating manual before use



Labels and symbols

	<p>Maximum working load Patient weight shall not exceed 150kg</p>
	<p>Do not sit on the side parts of the stretcher</p>



Routine maintenance

The recommended frequency of these maintenance procedures will depend on how often the equipment is used. It's good practice to establish these procedures and then adjust the frequency as your conditions indicate.

Before every use

Visual inspection of the TR9650 bath lift:

- Make sure that it stands securely on the floor.
- Make sure that it is possible to raise and lower the lift.
- Make sure that there are no damages on seat, backrest, arm supports, safety belts etc. that might hurt the patient.

Daily maintenance:

- Clean the lift according to the cleaning instructions. See table of contents, "Cleaning instructions".
- Charge the batteries daily or whenever the lift is not in use.
The batteries can't be overcharged.
See table of contents, "Charging instructions".

Monthly maintenance:

- Make sure that all screw and fastenings are tightened properly.

Annual maintenance:

- **Perform an annual maintenance according to the check list in the Service and Maintenance manual, for example:**
- Visual inspection of the drive belt, Auto stop test etc.

If you don't have the Service and maintenance manual, contact TR Equipment or your TR Equipment representative to get a new one. See contact info on www.trequipment.com.



Routine maintenance

Maintenance Every 3 years

- Repeat **Before every use, Daily-, Monthly- and Annual maintenance.**

Replace following parts:

- Replace both 12V batteries Part.no: 819030.
- Replace the drive belt Part.no: 7418124

Batteries

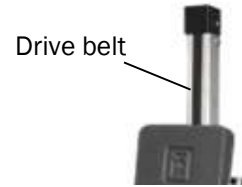

Maintenance Every 5 years

- Repeat Before every use, Daily-, Monthly- and Annual maintenance.

Replace following parts:

- Replace castors:
Castors with brake Part.no: 851760
Straight steering castors Part.no: 851761
- Replace the lifting motor Part.no: 2419640

Lifting motor



Castors with brake, Grey pedal



Straight steering castors, Black pedal



Warranty

Maintenance and/or repairs may only be carried out by the manufacturer or qualified staff authorized by the manufacturer, otherwise warranty expires immediately.



Disposal / Recycling

Recycling of the equipment

- Pillow is produced in lacquered PVC fabrics and filling materials are in Polytene. Pillow and shall be recycled as flammable materials.
- Seat and side parts are produced in Polyurethane and shall be recycled as flammable materials.
- Metal parts shall be recycled in Metal recycling
- Grey cover and fenders are produced in ABS plastic and shall be recycled as flammable materials.
- Castors are produced in Polyurethane and shall be recycled as flammable materials.
- Bolts shall be recycled as metal parts.



Important

When replacing batteries, deposit the batteries in accordance with national regulations.



Important

When replacing electrical and electronic parts/components, deposit the parts/components in accordance with national regulations.

Recycling of packaging materials.

- Wrapping materials is well and a wooden pallet.
- Well shall be recycled as recycled paper and pallet shall be recycled as wooden materials



Cleaning instructions

General guidelines for cleaning detergent

- Nonabrasive type of detergent
- Less than 5 Wt% chloride content
- Less than 3 Wt% alcohol content

**Warning**

Never use solvent based or strong alkaline cleaning liquids, which can damage or stain the pad and pillow surfaces.

**Warning**

Never clean pads and/or pillow in gas sterilization unit.
Safety belts may be machine washed and dried. Stretcher pillow Velcro strap **must be** pressed together during washing and drying to preserve their gripping power.

**Important**

The user/operator is responsible selecting the correct cleaning liquid/detergent and additives according to local regulations and safety standards. Please read the cleaning liquid/detergent supplier's instruction manual and find out whether the product is suitable for use with this product.



Cleaning instructions

Chair Lift

The User/operator is responsible for selecting the detergents and additives. Please read the detergent supplier's instruction manual and find out whether the product is suitable or not.

Do not use solvent based cleaning liquids, which can damage or stain the pad and pillow surfaces.

For thorough cleaning, remove the backrest pad and clean it in the bathtub.

For thorough cleaning, position the chair lift seat over the bathtub. If possible, use the tub's cleaning system otherwise use a spray bottle. Spray cleaning detergent on, and underneath the chair lift seat and between the chair lift seat and frame. If necessary, unscrew the seat from the frame. Rinse Chair, backrest pad with fresh water from the patient shower after cleaning. Wipe beneath the lift to prevent water dripping on floor.

Clean the chair lift and back rest pad after every use with mixed, nonabrasive type of detergent, according to instructions from the detergent supplier.

Do not use solvent based cleaning liquids which can damage or stain pads and seat.

Use a sponge or brush, and promptly remove any soap or lime deposits, and faeces to avoid spots/stains. Always rinse thoroughly with fresh water after using cleaning detergents.

Safety belts may be machine washed and dried. Stretcher pillow Velcro strap must be pressed together during washing and drying to preserve their gripping power.





Cleaning instructions

Stretcher- and Combi Lift

The User/operator is responsible for selecting the detergents and additives. Please read the detergent supplier's instruction manual and find out whether the product is suitable or not.

Do not use solvent based cleaning liquids, which can damage or stain the pad and pillow surfaces.

The Stretcher has removable side parts. The head pillow, made of PVC, is heat sealed against moisture and can be washed and cleaned.

For thorough cleaning, position the stretcher over the bathtub. If possible, use the tub's cleaning system, otherwise use a spray bottle. Spray cleaning detergent on and underneath the seat and between the sitting pad and frame. If necessary, unscrew the sitting pad from the frame. Rinse the stretcher, pillow, and pads thoroughly with fresh water from the patient shower after cleaning. Wipe beneath the lift to prevent water dripping on floor.

Clean the stretcher lift and pillow after every use with mixed, nonabrasive type of detergent, according to instructions from the detergent supplier.

Do not use solvent based cleaning liquids which can damage or stain pads and seat.

Use a sponge or brush, and promptly remove any soap or lime deposits, and faeces to avoid spots/stains. Always rinse thoroughly with fresh water after using cleaning detergents.

Safety belts may be machine washed and dried. Stretcher pillow Velcro strap must be pressed together during washing and drying to preserve their gripping power.

